

HIGH PERFORMANCE GYRO SENSOR

$\pm 250 \text{ }^\circ/\text{s}$ / $\pm 100 \text{ }^\circ/\text{s}$

Features

- Horizontal or vertical mounting
- High reliability and robustness over long lifetime
- Low vibration sensitivity
- High overload and shock capability (5000 g)
- Butterfly balanced designed for high mechanical common mode rejection
- Closed-loop force feedback operation with electrostatic frequency tuning
- Low bias drift
- Low noise
- Ideal mono crystalline Si material
- Wafer level sealing with controlled Q-factor
- Low power
- Single voltage supply +5VDC
- Fully digital with SPI communication and on-ship OTP calibration
- Digitally controlled sample rate up to 2000 SPS
- Bandwidth defined by built in 4th order digital LP filter
- Intrinsic continuous diagnostics monitoring
- Temperature sensor



(Scale 4:1)

Description

SAR100 contains a ButterflyGyro™ MEMS die and a BiCMOS mixed mode ASIC, housed in a rigid custom ceramic LCC package to accommodate for either horizontal or vertical mount. The sensor is factory-calibrated and compensated for temperature effects to provide high-accuracy digital output over a broad temperature range.

Perfect tuning of the excitation and detection frequency as well as perfect mechanical and electrical balancing the dual masses result in very low sensitivity to vibration and shock.

By utilizing a unique sealed cavity technology, the vibrating masses are contained within the low-

pressure hermetic environment needed for creating low dynamic damping and high Q-factors, without any degradation over the lifetime of the device whatever tough environmental conditions.

SAR100 is a product with high bias and scale factor stability, designed for demanding applications. The sensor is highly rugged, consuming as little power as 50 mW, offering the best value of any gyro product in its class of performance.

The in-run bias stability of SAR100 is 0.02 $^\circ/\text{s}$.

SPI interface of the sensor enables easy and effective communication to the application. Angular rate data output is 12-bit 2's complement, at a maximum rate of 2000 samples per second. A number of functions are available through the digital SPI interface including advanced self diagnostics.

SAR100

SPECIFICATIONS

Parameter	Min	Nom	Max	Unit
Weight		1.5		g
Functional characteristics				
Input range (ΩFSI)		± 250 ± 100		°/s °/s
Operating temperature	- 40		90	°C
Power supply	4.45	5.0	5.5	V
Supply current			17	mA
Start-up time		90		ms
Maximum sampling frequency		2000		SPS
Storage temperature	- 55		125	°C
Dynamic overload		5000		°/s
Mechanical shock			5000	g
Angular rate measurements				
Word length		12		bit
Scale factor	± 250 °/s (ΩFSI) ± 100 °/s (ΩFSI)	0.25 0.10		°/s/LSB °/s/LSB
Scale factor temperature accuracy		± 0.5		%
Bias temperature accuracy		± 0.5		°/s
Sensitivity accuracy		± 1		%
In-run bias stability		0.02		°/s
Noise	± 250 °/s (ΩFSI) ± 100 °/s (ΩFSI)	0.25 0.15		°/s (rms) °/s (rms)
Bandwidth (- 3dB)		50		Hz
Non-linearity		0.1		%FS
G sensitivity			0.05	°/s/g
Temperature measurements				
Word length		8		bit
Scale factor		1		°C/LSB
Accuracy		± 2		°C
SPI interface				
Datarate			8.5	Mbit/s

MECHANICAL DIMENSIONS

All dimensions in mm. The sensitive axis is indicated with arrow and sign.

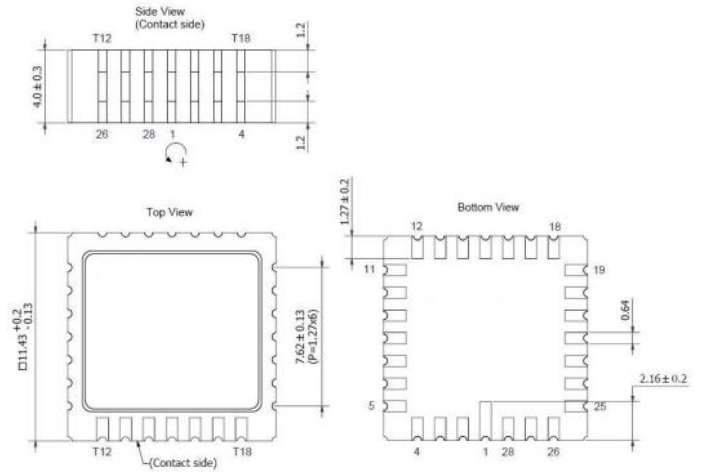

PIN OUT

Horizontal mount	Vertical mount	Pin name	Comment
1	1	GND	Connect to ground
2	2	AVSS	Connect to ground
3	3		Connect to ground
4	4	REFV	Connect a 10 nF low ESR decoupling capacitor between this pin and ground
5			NC
6			NC
7			NC
8			NC
9			NC
10			NC
11			NC
12	T18		Connect to ground
13	T17		Connect to ground
14	T16	AVDD	Connect to +5 VDC ¹⁾
15	T15		NC
16	T14	VDD	Connect to +5 VDC ¹⁾
17	T13	MOSI	SPI data input
18	T12	MISO	SPI data output
19			Connect to ground
20			Connect to ground
21			Connect to ground
22			NC
23			Connect to ground
24			Connect to ground
25			Connect to ground
26	26	SCLK	SPI clock
27	27	LOAD	SPI load
28	28	VSS	Connect to ground

ELECTRICAL CONNECTIONS

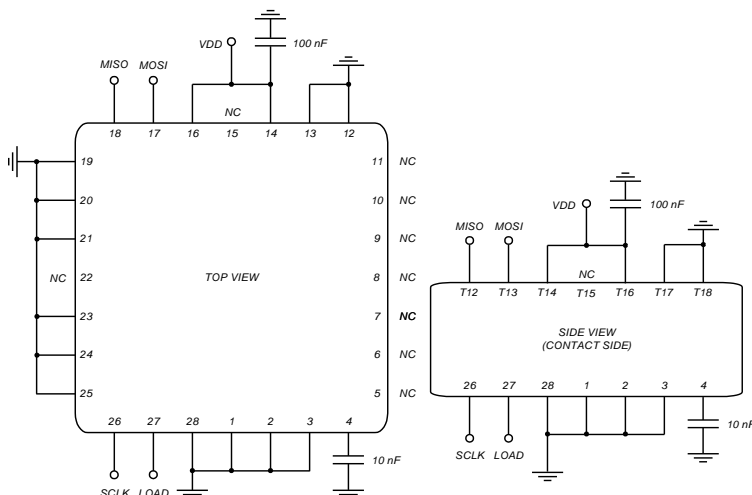

1) Connect these pins together on the PCB, as close to the package as possible, and from there a 100 nF low ESR decoupling capacitor to ground

CONTACT INFORMATION

Sensoror Technologies AS
 Phone: +47 3303 5000 - Fax: +47 3303 5005
 sales@sensoror.no www.sensoror.com