

Distribution	Prepared by Ronny Weum		Document No 09103001	
	Sign (RoW)	Date 29.01.10	Page of	1 4
Document Title SP300 sample program				

Table of Contents

1	Introduction	1
2	Sample program description	1
3	Example of reported datagram	3
4	Electrical connections	4

1 Introduction

This note describes the pre-programmed sample program of SP300, enabling quick measurement data access without having the evaluation and development kit available. Simply one pull-up resistor and a RS232 level converter are needed to be able to read the reported datagrams from SP300 into practically any PC serial port with this program.

2 Sample program description

An *asynchronous*, RS232 compatible, transmission mode is provided by this software. This is enabled by pulling P11 (pin 3 of SP300) externally high before power-on.

Note: A pull-up resistor of ~ 47 kΩ is recommended for setting P11 to a 'high' level.

The sample program measures pressure, temperature, supply voltage, and acceleration (optional).

Note: If acceleration is not supported by the SP300 derivative received, the reported acceleration values are considered "don't care" values.

The datagrams are reported on P14 (pin 11 of SP300) when program is running. Both raw and compensated data are included, however, normally only the compensated data is of interest. P17 (pin 9 of SP300) indicates transmission ON/ OFF, being at a 'high' level when transmissions is on.

The datagram content is described in Table 1. The start of the datagram is always 0xFF, 0xFE (synchronization bytes), followed by sensor ID, status, measured data and software revision. At the end of the datagram there are two bytes of CRC16, generated by the polynomial $G(x) = x^{16} + x^{12} + x^5 + 1$. The same polynomial can be used on the receiver side for comparison and to validate data received.

The total number of bytes in the datagram is 26. Transmission data rate is 9600 baud, with 1 start bit ("0") and 1 stop bit ("1"), thus the user can expect ~ 27 ms duration from datagram start to end.



Note: The specification of the internal RC oscillator of SP300, which determines the data rate of the reported datagrams, does not guarantee RS232 9600 baud compatibility over the entire temperature range of SP300 (-40 to 125 °C). A test program with a synchronous mode implemented, supporting an external clock source, is therefore recommended for this.

Table 1: SP300 sample program datagram content.

Byte 1	Datagram_Sync1	dsb	1	; 1st sync byte. Always 0xFF
Byte 2	Datagram_Sync2	dsb	1	; 2nd sync byte. Always 0xFE
Byte 3	Datagram_Id3	dsb	1	; MSB Sensoror Id
Byte 4	Datagram_Id2	dsb	1	
Byte 5	Datagram_Id1	dsb	1	
Byte 6	Datagram_Id0	dsb	1	; LSB Sensoror Id
Byte 7	Datagram_Status	dsb	1	; Status byte
Byte 8/9	Datagram_Raw_Pressure	dsw	1	; Raw Pressure data
Byte 10/11	Datagram_Raw_Temp	dsw	1	; Raw Temperature data
Byte 12/13	Datagram_Raw_VBatt	dsw	1	; Raw Supply Voltage data
Byte 14/15	Datagram_Raw_Accel	dsw	1	; Raw Acceleration data
Byte 16/17	Datagram_Comp_Pressure	dsw	1	; Compensated Pressure data
Byte 18/19	Datagram_Comp_Temp	dsw	1	; Compensated Temperature data
Byte 20/21	Datagram_Comp_VBatt	dsw	1	; Compensated Supply Voltage data
Byte 22/23	Datagram_Comp_Accel	dsw	1	; Compensated Acceleration data
Byte 24	Datagram_SW_Rev	dsb	1	; Firmware revision
Byte 25/26	Datagram_CRC16	dsb	2	; Checksum. Calc. on byte 3 to 24

Where;

- dsb is one byte of data
- dsw is two bytes of data



3 Example of reported datagram

An example of reported SP300 sample program datagram is shown (Figure 1).

The vertical axis has the unit [mA] to indicate SP300 current consumption, while horizontal axis has the unit [ms].

The software tool used to visualize the datagram also measures the current drawn by SP300 (green signal). For the trained eye this also indicates that SP300 is always in 'run' mode with this sample program running, however both idle and power down modes are supported by SP300 for current saving purposes.

In the plot, P11 is high (yellow signal), and datagrams are continuously reported on P14 (red signal). P17 (purple signal) indicates transmission is ON/OFF.

Datagrams are transmitted every ~ 51 ms, giving approximately 20 samples pr. second.

Freeware terminal programs "as is" are available for decoding purpose of SP300 sample program datagram, or customers can use own solutions.

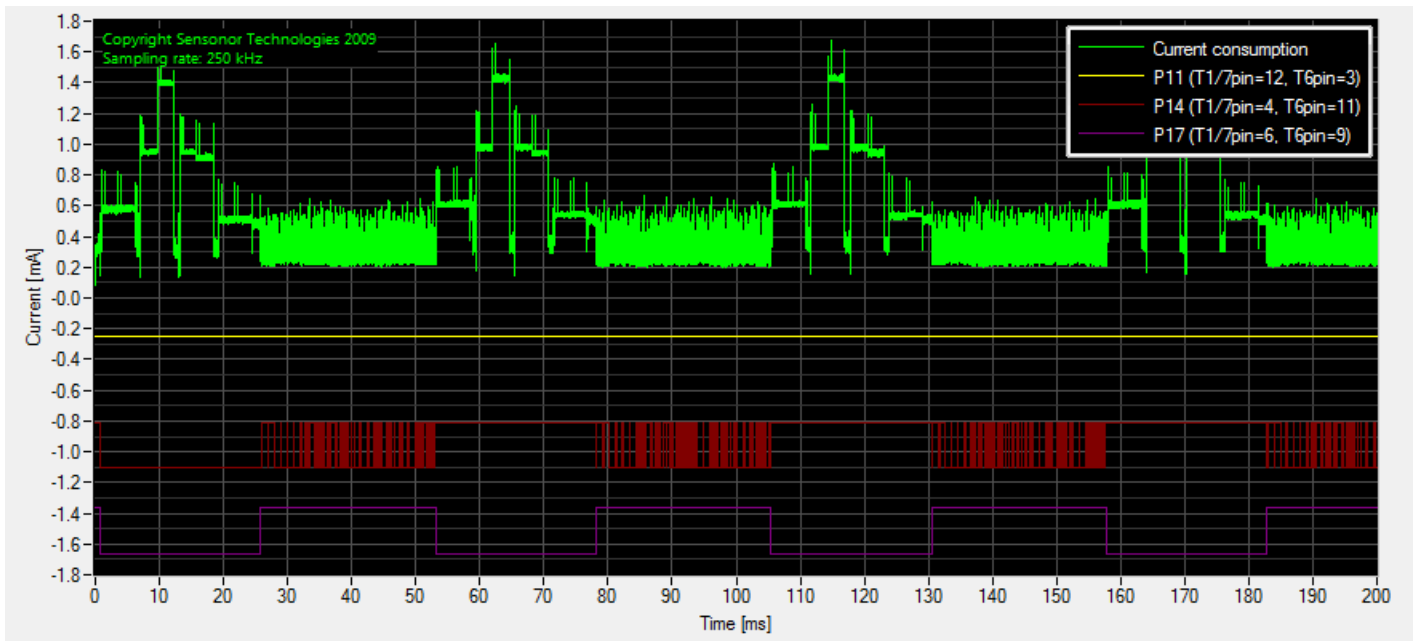

Figure 1: SP300 current consumption (green), pull-up resistor on P11 (yellow), transmitted datagram on P14 (red), and transmission ON/OFF signal on P17 (purple).



4 Electrical connections

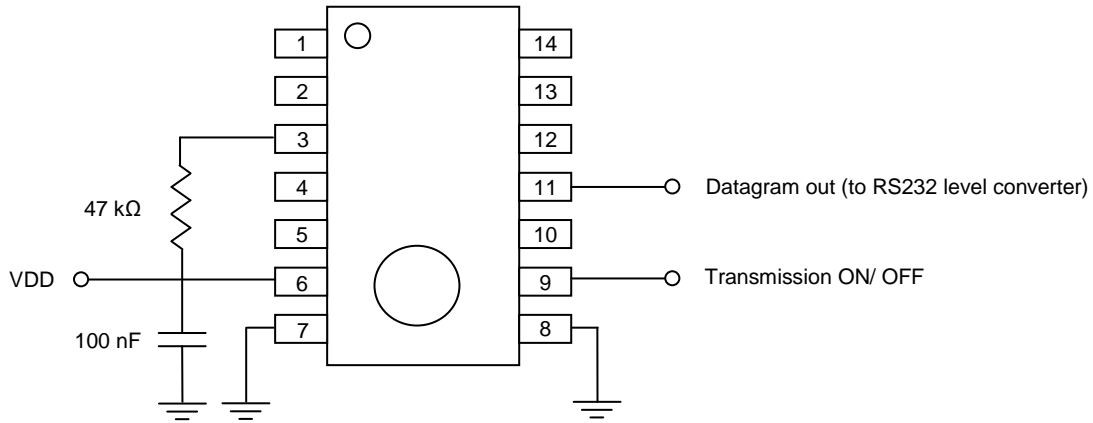

Figure 2: Electrical connections for SP300 sample datagram readout.